

# S4300

2020-UP TOYOTA SUPRA, 3.0L,  
CAT-BACK, 3.0" DUAL REAR OUTLET,  
DUAL TIP

# MBRP<sup>®</sup>

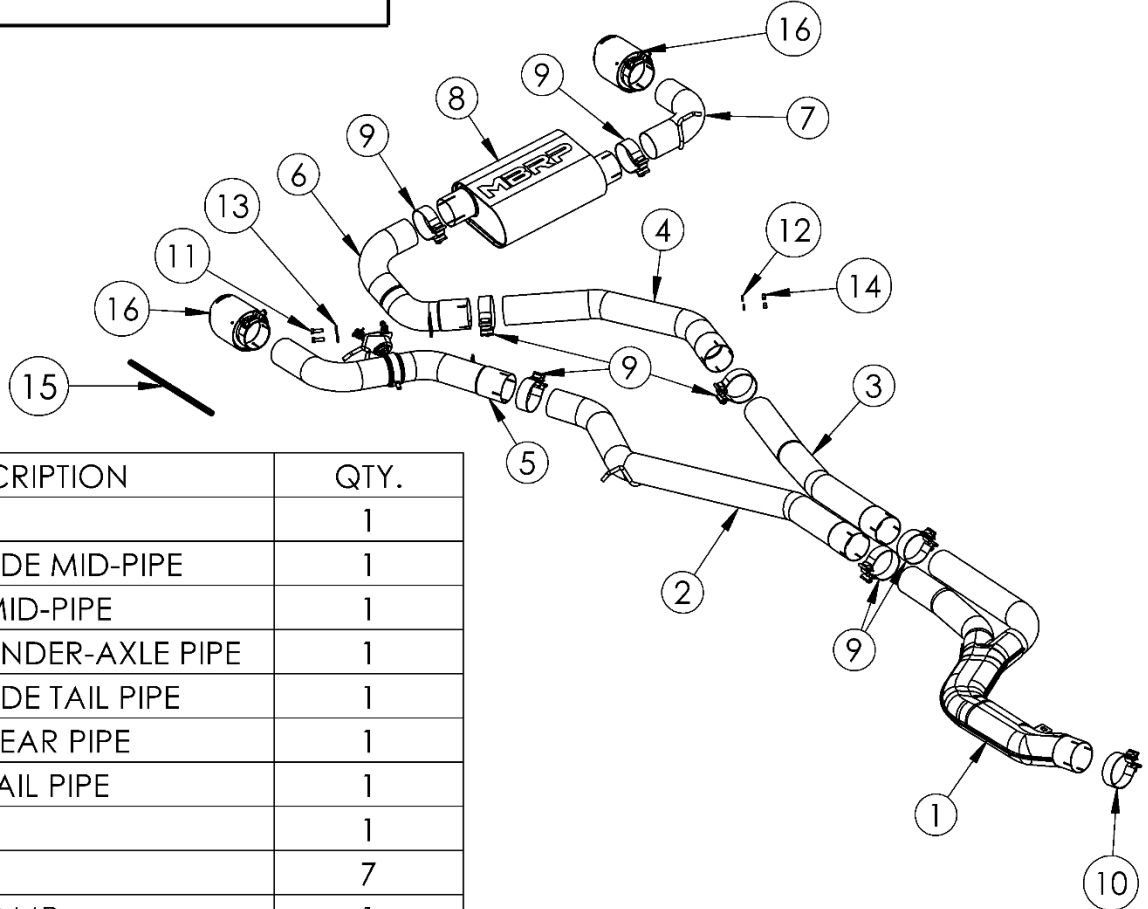

ITEM	DESCRIPTION	QTY.
1	Y-PIPE	1
2	PASSENGER-SIDE MID-PIPE	1
3	DRIVER-SIDE MID-PIPE	1
4	DRIVER-SIDE UNDER-AXLE PIPE	1
5	PASSENGER-SIDE TAIL PIPE	1
6	DRIVER-SIDE REAR PIPE	1
7	DRIVER-SIDE TAIL PIPE	1
8	MUFFLER	1
9	3.0" CLAMP	7
10	3.2" BAND CLAMP	1
11	5/16" HEX BOLT X 1"	2
12	5/16" LOCK WASHER	2
13	5/16" FLAT WASHER	2
14	5/16" HEX NUT	2
15	SPLIT WIRE LOOM	1
16	TIP	2

## PLEASE READ BEFORE STARTING INSTALLATION

**While MBRP has made every effort to ensure that all components of this system are of superior quality and properly packaged, it is the installer's responsibility to ensure the following before removal of the factory exhaust:**

- that ALL components shown above are present.
- that ALL mating components fit together.
- that there are no damaged components.
- that the system you have purchased is appropriate for your vehicle year, model and configuration.
- that the system will not interfere with any modifications previously installed or planned.
- that you have read and understand these instructions.

If you have any questions or are uncertain about any aspect of the installation of this system to your vehicle please contact your dealer before commencing installation.

# MBRP

## Removal of Stock System

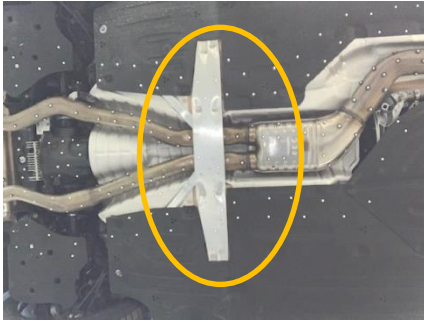

**Figure 1**



**Figure 2**



**Figure 3**



**Figure 4**

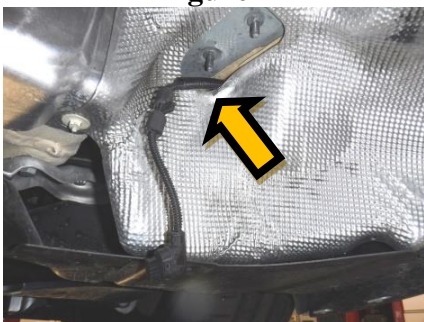

**Figure 5**

1. Apply penetrating lubricant liberally to all exhaust fasteners, hangers and rubber insulators.

2. Remove cross-bracing after factory Y-pipe to allow clearance for removal.

**Refer to Figure 1.**

3. Disconnect the exhaust valve actuator wiring.

**Refer to Figure 2.**

4. Loosen the factory band clamp that joins the Y-pipe to the down pipe.

5. Remove the single nut from the center hanger. Save all factory hardware as it is used for the installation.

**Refer to Figure 3.**

6. With the exhaust system supported, remove the nut on the Y-pipe insulator, and the 4 nuts retaining the two rear hangers.

7. Carefully remove the exhaust from the vehicle, ideally you have two helpers, one at each tip as you disengage the Y-pipe from the down pipe and guide the exhaust out from under the vehicle.

8. Remove the factory exhaust valve actuator from the exhaust system to be installed on the new system.

9. Reinstall the factory cross-bracing.

**Refer to Figure 1.**

## Installation of MBRP Performance Exhaust

1. Remove the exhaust valve actuator wiring clip from the passenger-side rear heat shield and remove the heat shield from the vehicle. Unclip the wiring retainers to allow the wiring to hang freely. Install the **Split Wire Loom** from the wiring clip closest to the actuator connector up to the vehicle wiring harness.

**Refer to Figure 4.**

2. Route the exhaust valve actuator wiring around behind the heat shield and out the hole for the passenger-side rear hanger, then reinstall the heat shield.

**Refer to Figure 5.**

# MBRP



Figure 6

3. Using the **3.2" Band Clamp**, loosely install the **Y-Pipe** onto the factory down pipe and the front insulator. Loosely install the factory front insulator nut. Support the **Y-Pipe** outlets.  
**Refer to Figure 6.**

4. Place two **3" Clamps** on the **Y-Pipe** outlets.

5. Transfer the factory center hanger onto the **Passenger-Side Mid-Pipe**. Loosely install the **Passenger-Side Mid-Pipe** onto the **Y-Pipe** and reinstall the factory center hanger onto the vehicle.

**Refer to Figure 7.**



Figure 7

6. Transfer the factory passenger-side rear hanger onto the **Passenger-Side Tail Pipe** hanger.

7. Install the exhaust valve actuator onto the **Passenger-Side Tail Pipe** using the supplied hardware and **Drive Spring**. Ensure the **Drive Spring** is on the valve hub and lined up with valve actuator slot and oriented as pictured.

**Refer to Figure 8.**



Figure 8

8. Using **3.0" Band Clamp**, loosely install the **Passenger-Side Tail Pipe** onto the **Passenger-Side Mid-Pipe** and re-attach the factory hanger to the vehicle using factory hardware and reconnect the exhaust valve actuator wiring.  
**Refer to Figure 9.**

9. Loosely attach the **Driver-Side Mid-Pipe** to the **Y-Pipe** and place a **3.0" Clamp** on the outlet.  
**Refer to Figure 10.**



Figure 9

10. Loosely attach the **Driver-Side Under-Axle Pipe** to the **Driver-Side Mid-Pipe** and place a **3.0" Clamp** on the outlet.  
**Refer to Figure 11.**

11. Loosely install the **Driver-Side Rear Pipe** onto the **Driver-Side Under-Axle Pipe** using the **3.0" Clamp**. Using the **5/16" Hardware** provided, loosely attach the mounting bracket to the **Passenger-Side Tail Pipe**. You will need to rotate the pipe to line up the bracket. The **Driver-Side Rear Pipe** bracket goes to the rear side of the **Passenger-Side Tail Pipe** bracket.  
**Refer to Figure 12.**



Figure 10

# MBRP



**Figure 11**

**12.** Using a **3.0" Clamp**, loosely install the **Muffler**. It should be angled up about 10 degrees, higher at the rear of the car.  
**Refer to Figure 13.**

**13.** Transfer the factory driver-side rear hanger onto the **Driver-Side Tail Pipe** hanger and using a **3.0" Clamp**, install the **Driver-Side Tail Pipe** into the **Muffler** and re-attach the factory hanger to the vehicle using factory hardware.

**Refer to Figure 14.**



**Figure 12**

**14.** Loosely install the **Tips**.  
**Refer to Figure 15.**

**15.** Carefully align the system and tips. There will be some twisting and turning of the **Driver-Side Mid-Pipe** and **Driver-Side Under-Axle Pipe** to maximize clearance. Tighten all hardware and clamps, starting at the front and working rearward to secure the system. Check along the full length of the exhaust system to ensure there is adequate clearance for fuel lines, vent lines, brake lines, frame, bodywork, suspension and any wiring, etc. If there is any interference detected, relocate or adjust to provide adequate clearance. Ensure all clamp connections are secure and components are unable to rotate or slide. Band clamps require approximately 45 lb-ft (60 N-m) of torque. Verify clearances, system security and band clamp torque after 30-60 miles (50-100 km) of driving.

**NOTE:** Due to variances in exhaust valve actuator positions, you may experience a slight rattle at initial start-up. To set the exhaust valve actuator position, you may need to switch between Normal and Sport driving modes a few times. The engine needs to be warmed up and off of fast idle before modes change.



**Figure 13**



**Figure 14**



**Figure 15**



**Congratulations!** You are ready to begin experiencing the improved power, sound and driving experience of your **MBRP** Performance Exhaust. We know you will enjoy your purchase!